



KNIFE GATE VALVES

A LUG SERIES

HANDWHEEL with Rising Stem

- **B = max. width** of the valve (without actuator).
- D = max. height** of the valve (without actuator).

- Options:
 - Limiting switches.
 - Extensions: stand, pipe, plates,...
 - DN higher than those shown in the table.

- Actuator comprising:
 - Handwheel.
 - Stem.
 - Nut.
 - Stem protection hood.

- Available: DN50 to DN1200, other DN on request.

- From DN600 the actuator is with gears.

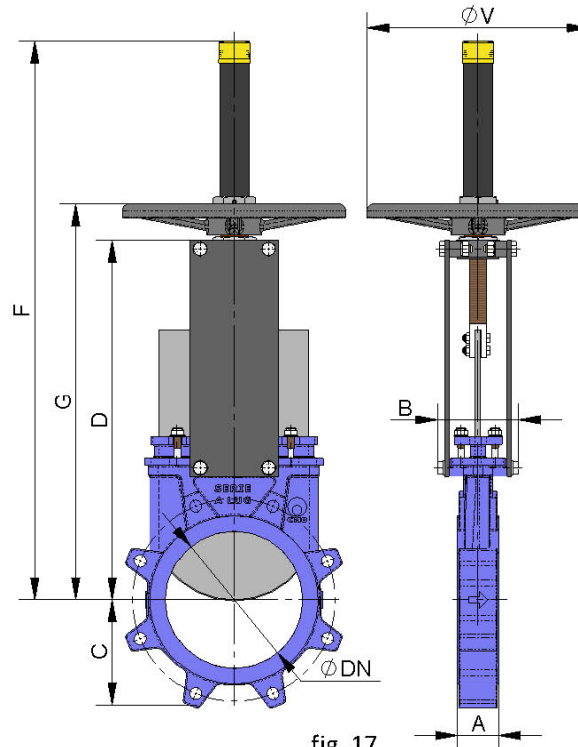

fig. 17

DN	ΔP (Kg/cm ²)	DRAW (Nw)	TORQUE (Nm)	A	B	C	D	F	G	ϕV
50	10	830	1,91	40	91	61	241	410	280	225
65	10	1400	3,22	40	91	68	268	437	308	225
80	10	2120	4,9	50	91	91	294	463	333	225
100	10	3310	7,61	50	91	104	334	503	373	225
125	10	5180	11,9	50	101	118	367	586	407	225
150	10	5970	14	60	101	130	419	638	458	225
200	8	9300	27	60	118	159	525	816	578	325
250	6	10400	30	70	118	196	626	1017	679	325
300	6	15000	43	70	118	231	726	1117	779	380
350	5	16380	63	96	290	257	797	1337	906	450
400	5	21430	83	100	290	290	903	1443	1012	450
450	3	20044	79	106	290	312	989	1629	1098	450
500	3	25230	98	110	290	340	1101	1741	1210	450
600	3	36510	142	110	290	398	1307	2047	1416	450
700	2	32945	180	110	320	453	1506	--	--	--
800	2	43493	238	110	320	503	1720	--	--	--
900	2	55024	301	110	320	583	1953	--	--	--
1000	2	68580	375	110	320	613	2137	--	--	--
1200	2	99026	643	150	340	728	2616	--	--	--

table 4